

DINGLI JCPT2212DC

SELF PROPELLED SCISSOR LIFT - ELECTRIC



SPECIFICATIONS

| Size | Metric | British |
|-------------------------------------|-------------|---------------------|
| Max. Working Height A | 22.00m | 72ft 2in |
| Max. Platform Height B | 20.00m | 65ft 7in |
| Overall Length C | 4.72m | 15ft 6in |
| Overall Width D | 1.25m | 4ft 1in |
| Overall Height(Rails Up) E | 3.82m | 12ft 6in |
| Overall Height(Rails Down) F | 2.99m | 9ft 10in |
| Platform Size(Length×Width) | 4.30m×1.19m | 14ft 1in × 3ft 11in |
| Platform Extension Size G | 1.80m | 5ft 11in |
| Ground Clearance(Stowed/Raised) | 0.20m/0.02m | 8in/1in |
| Wheelbase H | 3.18m | 10ft 5in |
| Turning Radius(Inside/Outside) | 1.6m/2.3m | 5ft 3in/7ft 7in |
| Tyres | 28×10-22 | 28×10-22 |

| Performance | | |
|----------------------|----------|----------|
| S.W.L | 750kg | 1653lb |
| S.W.L On Extension | 750kg | 1653lb |
| Max. Occupants | 2 | 2 |
| Gradeability | 25% | 25% |
| Travel Speed(Stowed) | 3.0km/h | 3.0km/h |
| Travel Speed(Raised) | 0.5km/h | 0.5km/h |
| Max. Working Slope | 1°(0°) | 1°(0°) |
| Up/Down Speed | 85/75sec | 85/75sec |

| Weight | | |
|----------------|---------|---------|
| Overall Weight | 12350kg | 27227lb |

| Power | | |
|----------------|----------------|----------------|
| Hydraulic Tank | 130L | 130L |
| Battery | 48V/630Ah | 48V/630Ah |
| Charger | 48V/60A | 48V/60A |
| Driving Motor | 4×AC 32V/3.3kW | 4×AC 32V/3.3kW |
| Lifting Motor | 2×DC 48V/8.0kW | 2×DC 48V/8.0kW |

* The platform height plus 2m (7ft in British standard) is the working height.
Standards Compliance

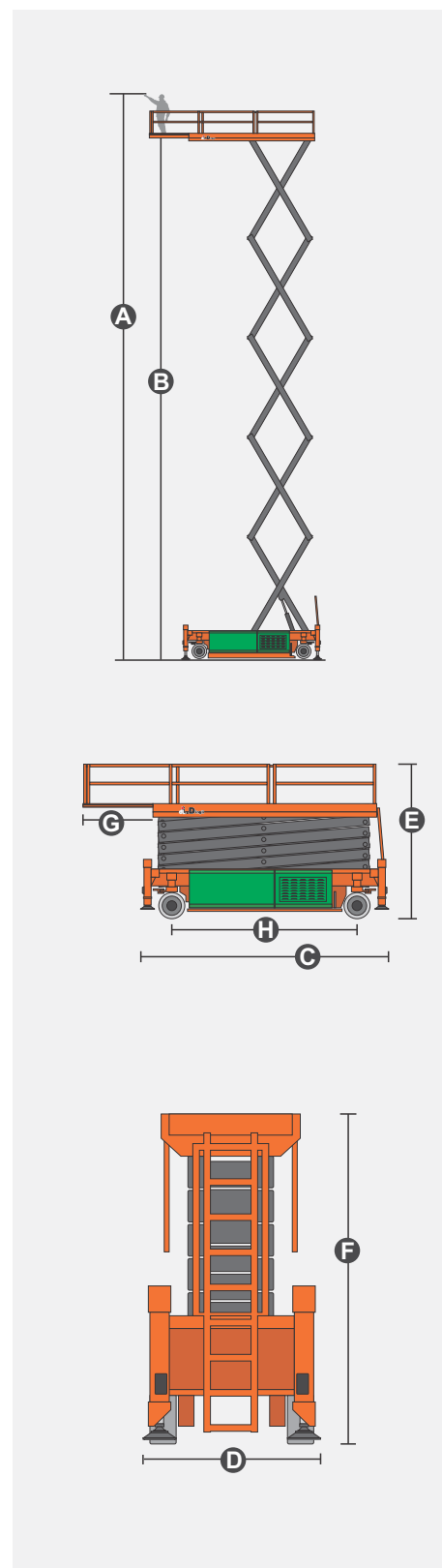

DINGLI JCPT2212DC

SELF PROPELLED SCISSOR LIFT - ELECTRIC



FEATURES

Standard Items

- Proportional Joystick Controls
- Self-Locking Gates
- One-Way Platform Extension Deck
- Drivable At Full Height
- Solid Rubber Tyres
- 4x4 Drive
- 4x4 Steer
- Four-Wheel Braking
- Self-Weight Lowering System
- Tubing Explosion-Proof System
- Onboard Fault Diagnostic System
- Tilt Alarm
- Motion Alarm
- Horn
- Hour Meter
- Charging Protection System
- Flashing LED Beacon
- Foldable Guard Rails
- Drive Enable
- Automatic One-Way Platform Extension Deck
- Manual Brake Release
- Lanyard Attachment Point
- Tie-Down And Lifting Points
- Automatic Leveling Hydraulic Outriggers
- Emergency Pump
- Emergency Stop Button
- Platform Load Sense System

Optional Items

- **Factory Hydraulic Oil**
- No. 46 Hydraulic Oil (Mineral Oil)**

Additional Items

- GPS Unit
- Biodegradable Hydraulic Oil
- AC Power Cord to Platform
- Air Line to Platform
- Work Light Package
- Footpedal Switch
- Anti-Collision Bar on Platform
- Visual Spirit Level
- Outrigger Pad Package
- Guard Mesh Package
- Self-Lubrication System