

DINGLI

AMWP9.5-1200

MAST BOOM LIFT - WHEEL

SPECIFICATIONS

Size	Metric	British
Max. Working Height A	9.50m	31ft 2in
Max. Platform Height B	7.50m	24ft 7in
Overall Length C	1.44m	4ft 9in
Overall Width D	0.80m	2ft 8in
Overall Height E	1.99m	
Platform Size(Length F /Width G)	0.73m×0.75m	2ft 5in×2ft 6in
Platform Extension Size H	0.53m	1ft 9in
Ground Clearance(Stowed)	0.06m	2in
Ground Clearance(Raised)	0.019m	1in
Wheelbase	1.12m	3ft 8in
Turning Radius(Inside/Outside)	0/1.60m	0/5ft 3in
Tyres	Φ323×100mm	Φ1ft 1in×4in

Performance		
S.W.L	136kg	299lb
Max. Occupants	1	1
Gradeability	25%	25%
Max. Working Slope	X-1.5° Y-3°	X-1.5° Y-3°
Travel Speed(Stowed)	4km/h	4km/h
Travel Speed(Raised)	1.1km/h	1.1km/h
UP/Down Speed	29/32sec	29/32sec

Weight		
Weight	1535kg	3384lb

Power		
Battery	2×12V/115Ah	2×12V/115Ah
Integrated Charger	24V/15A	24V/15A
Drive Motor	2×24VDC/1kW	2×24VDC/1kW
Lifting Motor	24VDC/2kW	24VDC/2kW

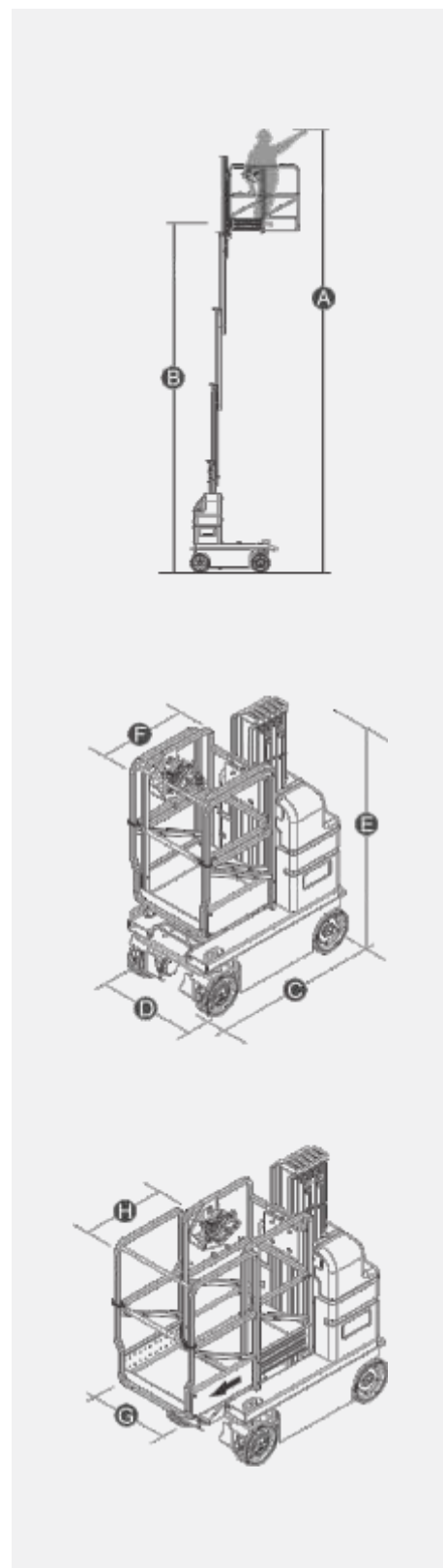

DINGLI

AMWP9.5-1200

MAST BOOM LIFT - WHEEL



FEATURES

Standard Items

- Proportional Joystick Controls
- Self-Locking Gates
- One-Way Platform Extension Deck
- Drivable At Full Height
- Non-Marking Tires
- 4x2 Drive
- Automatic Braking System
- Emergency Descent System
- Tubing Explosion-Proof System
- Fault Diagnosis System
- Tilt Alarm
- Motion Alarm
- Horn
- Hour Meter
- Standard Transport Forklift Holes
- Charging Protection System
- Flashing Beacon
- Automatic Pothole Protection
- Drive Enable
- Charging Indicator
- Manual Brake Release
- Lanyard Attachment Point
- Tie-Down And Lifting Points
- Platform Load Sense System
- Emergency Stop Button

Additional Items

- Biodegradable Hydraulic Oil
- AC Power Cord to Platform
- Air Tube to Platform

