

DINGLI JCPT1912DC

SELF PROPELLED SCISSOR LIFT - ELECTRIC



SPECIFICATIONS

Size	Metric	British
Max. Working Height A	19.00m	62ft 4.0in
Max. Platform Height B	17.00m	55ft 9in
Overall Length C	4.72m	15ft 6in
Overall Width D	1.25m	4ft 1in
Overall Height(Rails Up) E	3.57m	11ft 9in
Overall Height(Rails Down) F	2.74m	9ft
Platform Size(Length×Width)	4.30m×1.19m	14ft 1in × 3ft 11in
Platform Extension Size G	1.80m	5ft 11in
Ground Clearance(Stowed/Raised)	0.20m/0.02m	8in/1in
Wheelbase H	3.18m	10ft 5in
Turning Radius(Inside/Outside)	1.60m/2.30m	5ft 3in/7ft 7in
Tyres	28×10-22	28×10-22

Performance		
S.W.L	750kg	1653lb
S.W.L On Extension	750kg	1653lb
Max. Occupants	2	2
Gradeability	25%	25%
Travel Speed(Stowed)	3.0km/h	3.0km/h
Travel Speed(Raised)	0.5km/h	0.5km/h
Max. Working Slope	1°(0°)	1°(0°)
Up/Down Speed	75/72sec	75/72sec

Weight		
Overall Weight	11750kg	25904lb

Power		
Hydraulic Tank	130L	130L
Battery	48V/630Ah	48V/630Ah
Charger	48V/60A	48V/60A
Driving Motor	4×AC 32V/3.3kW	4×AC 32V/3.3kW
Lifting Motor	2×DC 48V/8.0kW	2×DC 48V/8.0kW

* The platform height plus 2m (7ft in British standard) is the working height.
Standards Compliance

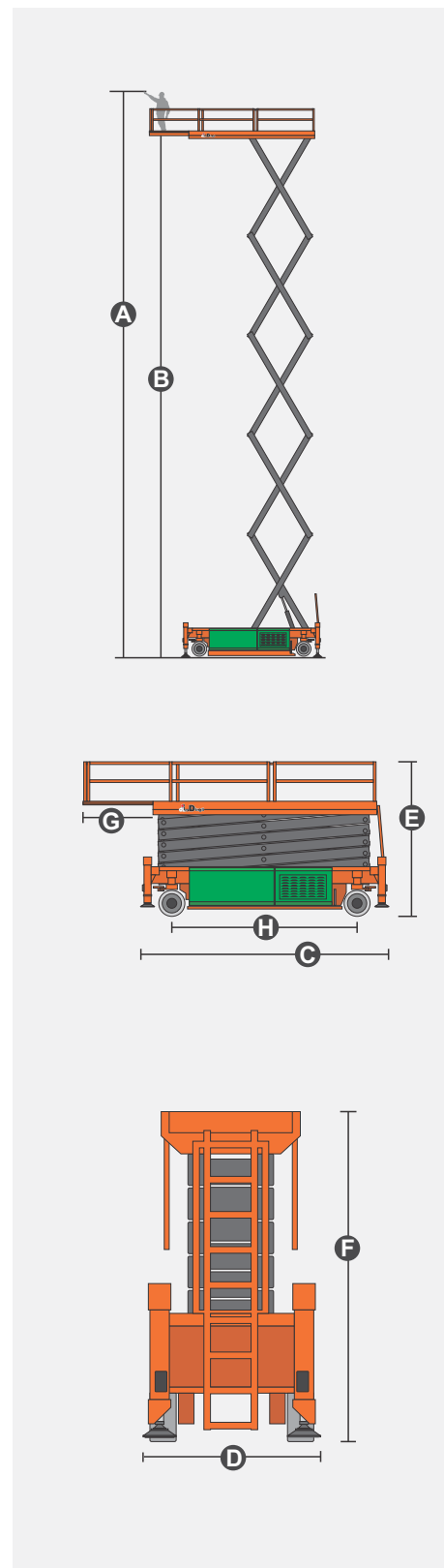

DINGLI JCPT1912DC

SELF PROPELLED SCISSOR LIFT - ELECTRIC



FEATURES

Standard Items

- Proportional Joystick Controls
- Self-Locking Gates
- One-Way Platform Extension Deck
- Drivable At Full Height
- Solid Rubber Tyres
- 4x4 Drive
- 4x4 Steer
- Four-Wheel Braking
- Self-Weight Lowering System
- Tubing Explosion-Proof System
- Onboard Fault Diagnostic System
- Tilt Alarm
- Motion Alarm
- Horn
- Hour Meter
- Charging Protection System
- Flashing LED Beacon
- Foldable Guard Rails
- Drive Enable
- Automatic One-Way Platform Extension Deck
- Manual Brake Release
- Lanyard Attachment Point
- Tie-Down And Lifting Points
- Automatic Leveling Hydraulic Outriggers
- Emergency Pump
- Emergency Stop Button
- Platform Load Sense System

Optional Items

Additional Items

- GPS Unit
- Biodegradable Hydraulic Oil
- AC Power Cord to Platform
- Air Line to Platform
- Work Light Package
- Footpedal Switch
- Anti-Collision Bar on Platform
- Visual Spirit Level
- Outrigger Pad Package
- Guard Mesh Package
- Self-Lubrication System